



- UL 1077 and UL 489 certified versions
- High breaking capacity
- Various trip characteristic curves: Type B, C or D
- Wide 1...125A current range
- Residuals with trip characteristic curves type A, AC and B
- Switch disconnectors
- Accessories available.

	<b>SEC. - PAGE</b>
<b>Miniature circuit breakers 1...63A, UL 1077</b>	
1P - 10kA, 1 module, curve types B, C and D .....	14 - 2
1P+N - 6kA, 1 module, curve type C .....	14 - 3
1P+N - 6kA, 2 modules, curve type C .....	14 - 3
2P - 10kA, 2 modules, curve types B, C and D .....	14 - 4
3P - 10kA, 3 modules, curve types B, C and D .....	14 - 5
4P - 10kA, 4 modules, curve types B, C and D .....	14 - 6
<b>Miniature circuit breakers 1...63A, UL 489</b>	
1P - 10kA, 1 module .....	14 - 7
2P - 10kA, 2 modules .....	14 - 8
3P - 10kA, 3 modules .....	14 - 9
<b>Miniature circuit breakers 80...125A, UL 1077</b>	
1P, 2P, 3P and 4P - 10kA, curve type C .....	14 - 10
3P and 4P - 10kA, curve type D .....	14 - 10
<b>Add-on blocks and accessories</b> .....	14 - 11
<b>Modular switch disconnectors</b> .....	14 - 13
<b>Residual blocks</b> .....	14 - 13
<b>Residual current operated circuit breakers</b> .....	14 - 14
<b>Residual current operated circuit breakers with overcurrent protection</b> .....	14 - 15
<b>Dimensions</b> .....	<b>14 - 16</b>
<b>Wiring diagrams</b> .....	<b>14 - 16</b>
<b>Technical characteristics</b> .....	<b>14 - 17</b>



Page 14-2

**MINIATURE CIRCUIT BREAKERS UP TO 63A**

- 1P, 1P+N, 2P, 3P and 4P versions
- IEC rated current  $I_n$ : 1...63A
- IEC short-circuit breaking capacity  $I_{cn}$ : 10kA (6kA for 1P+N)
- Trip characteristic curve: Type B, C, D
- UL 1077 or UL 489 certified versions.



Page 14-10

**MINIATURE CIRCUIT BREAKERS 80...125A**

- 1P, 2P, 3P and 4P versions
- IEC rated current  $I_n$ : 80...125A
- IEC short-circuit breaking capacity  $I_{cn}$ : 10kA
- Trip characteristic curve: Type C, D
- UL 1077 certified versions.



Page 14-11

**ADD-ON BLOCKS AND ACCESSORIES**

- Auxiliary and indicator contacts
- Undervoltage trip releases
- Shunt trip releases
- Connection accessories.



Page 14-13

**SWITCH DISCONNECTORS**

- 1P, 2P, 3P and 4P versions
- IEC rated current  $I_n$ : 32...125A
- Clear OFF contact status indication
- Auxiliary contact block available.



Page 14-13

**RESIDUAL BLOCKS FOR CIRCUIT BREAKERS UP TO 63A**

- 2P, 3P and 4P versions
- IEC rated current  $I_n$ : 40 and 63A
- Residual current: 30 and 300mA
- Residual current operating characteristic: Type A.



Page 14-14

**RESIDUAL CURRENT OPERATED CIRCUIT BREAKERS 25...63A**

- 2P and 4P versions
- IEC rated current  $I_n$ : 25, 40 and 63A
- IEC rated residual operating current  $I_{\Delta n}$ : 30mA and 300mA
- Residual current operating characteristic: Type A, B and AC
- Auxiliary contact and signalling contact blocks available.



Page 14-15

**RESIDUAL CURRENT OPERATED CIRCUIT BREAKERS WITH OVERCURRENT PROTECTION UP TO 40A**

- 1P+N versions
- IEC rated current  $I_n$ : 6...40A
- IEC rated short-circuit capacity  $I_{cn}$ : 10kA
- Trip characteristic curve: Type C
- Residual current: 30 and 300mA
- Residual current operating characteristic: Type AC and A
- Auxiliary contact and signalling contact blocks available.

### 1P - 10kA (IEC/EN/BS) 1 module



P1MB1P...



Order code	Curve	IEC In	IEC Icn	N° of DIN module	Qty per pkg	Wt
		[A]	[kA]	n°	n°	[kg]

Single pole, thermal and magnetic trip type, B-curve characteristic.

P1MB1PB01	B	1	10	1	12	0.115
P1MB1PB02	B	2	10	1	12	0.115
P1MB1PB03	B	3	10	1	12	0.115
P1MB1PB04	B	4	10	1	12	0.115
P1MB1PB06	B	6	10	1	12	0.115
P1MB1PB08	B	8	10	1	12	0.115
P1MB1PB10	B	10	10	1	12	0.115
P1MB1PB13	B	13	10	1	12	0.115
P1MB1PB16	B	16	10	1	12	0.115
P1MB1PB20	B	20	10	1	12	0.115
P1MB1PB25	B	25	10	1	12	0.115
P1MB1PB32	B	32	10	1	12	0.115
P1MB1PB40	B	40	10	1	12	0.115
P1MB1PB50	B	50	10	1	12	0.115
P1MB1PB63	B	63	10	1	12	0.115

Single pole, thermal and magnetic trip type, C-curve characteristic.

P1MB1PC01	C	1	10	1	12	0.115
P1MB1PC01V6	C	1.6	10	1	12	0.115
P1MB1PC02	C	2	10	1	12	0.115
P1MB1PC03	C	3	10	1	12	0.115
P1MB1PC04	C	4	10	1	12	0.115
P1MB1PC06	C	6	10	1	12	0.115
P1MB1PC08	C	8	10	1	12	0.115
P1MB1PC10	C	10	10	1	12	0.115
P1MB1PC13	C	13	10	1	12	0.115
P1MB1PC16	C	16	10	1	12	0.115
P1MB1PC20	C	20	10	1	12	0.115
P1MB1PC25	C	25	10	1	12	0.115
P1MB1PC32	C	32	10	1	12	0.115
P1MB1PC40	C	40	10	1	12	0.115
P1MB1PC50	C	50	10	1	12	0.115
P1MB1PC63	C	63	10	1	12	0.115

Single pole, thermal and magnetic trip type, D-curve characteristic.

P1MB1PD01	D	1	10	1	12	0.115
P1MB1PD01V6	D	1.6	10	1	12	0.115
P1MB1PD02	D	2	10	1	12	0.115
P1MB1PD03	D	3	10	1	12	0.115
P1MB1PD04	D	4	10	1	12	0.115
P1MB1PD06	D	6	10	1	12	0.115
P1MB1PD08	D	8	10	1	12	0.115
P1MB1PD10	D	10	10	1	12	0.115
P1MB1PD13	D	13	10	1	12	0.115
P1MB1PD16	D	16	10	1	12	0.115
P1MB1PD20	D	20	10	1	12	0.115
P1MB1PD25	D	25	10	1	12	0.115
P1MB1PD32	D	32	10	1	12	0.115
P1MB1PD40	D	40	10	1	12	0.115
P1MB1PD50	D	50	10	1	12	0.115
P1MB1PD63	D	63	10	1	12	0.115

### General characteristics

These devices are used to protect against short circuits and overloads of wiring installations and loads in panel boards, office buildings, stores and similar applications.

Their purpose is circuit protection, circuit isolation and load operation controls. They have instantaneous trip characteristics defined as follows:

- B-curve: instantaneous trip 3...5 times In for non-inductive or low inductive loads (heating resistors, generators, very long wire lines)
- C-curve: instantaneous trip 5...10 times In for inductive loads (mixed and inductive resistive loads with low inrush current)
- D-curve: instantaneous trip 10...14 times In for highly inductive loads (loads with high inrush and current such as motors).

Main features include:

- IEC rated current In: 1...63A
- Pole width: 17.5mm / 0.69"
- Contact status with flag indicator
- Trip characteristic: curve type B, C and D
- Auxiliary contacts and trip releases mounted on MCB left side
- Fixing on 35mm DIN rail (IEC/EN/BS 60715).

### Operational characteristics

- Dissipation per pole: 3...13W
- IEC rated insulation voltage Ui: 440V
- IEC rated impulse voltage Uimp: 4kV
- IEC rated operational voltage Ue: 230/400VAC
- UL 1077 rated operational voltage: 277VAC
- Short circuit breaking capacity: IEC/EN/BS 10kA - UL 7.5kA 240V - 5kA 277V.

### Certifications and compliance

Certifications obtained: cURus (E369585); EAC; TÜV-Rheinland.

Compliant with standards: IEC/EN/BS 60898-1, IEC/EN/BS 60947-2, UL 1077, CSA C22.2 n°235.

### 1P+N - 6kA 1 module



P1MB1M...



Order code	Curve	IEC In	IEC Icn	N° of DIN module	Qty per pkg	Wt
		[A]	[kA]	n°	n°	[kg]

Single pole + neutral, thermal and magnetic trip type, B-curve characteristic.

P1MB1MB06	B	6	6	1	12	0.115
P1MB1MB10	B	10	6	1	12	0.115
P1MB1MB16	B	16	6	1	12	0.115
P1MB1MB20	B	20	6	1	12	0.115
P1MB1MB25	B	25	6	1	12	0.115
P1MB1MB32	B	32	6	1	12	0.115

Single pole + neutral, thermal and magnetic trip type, C-curve characteristic.

P1MB1MC02	C	2	6	1	12	0.115
P1MB1MC04	C	4	6	1	12	0.115
P1MB1MC06	C	6	6	1	12	0.115
P1MB1MC10	C	10	6	1	12	0.115
P1MB1MC13	C	13	6	1	12	0.115
P1MB1MC16	C	16	6	1	12	0.115
P1MB1MC20	C	20	6	1	12	0.115
P1MB1MC25	C	25	6	1	12	0.115
P1MB1MC32	C	32	6	1	12	0.115
P1MB1MC40	C	40	6	1	12	0.115

#### General characteristics

These devices are used to protect against short circuits and overloads of wiring installations and loads in panel boards, office buildings, stores and similar applications.

Their purpose is circuit protection, circuit isolation and load operation controls. They have characteristics of instantaneous trip defined as follows:

- B-curve: instantaneous trip 3...5 times  $I_n$  for non-inductive or low inductive loads (heating resistors, generators, very long wire lines)
- C-curve: instantaneous trip 5...10 times  $I_n$  for inductive loads (mixed loads, resistive and inductive with low inrush current)
- D-curve: instantaneous trip 10...14 times  $I_n$  for highly inductive loads (loads with high inrush and current such as motors).

Main features include:

- IEC rated current  $I_n$ : 2...40A
- Pole width: 9mm/0.35" (0.5 module)
- Contact status with flag indicator
- Trip characteristic: curve type B and C
- Auxiliary contacts and trip releases mounted on left side
- Fixing on 35mm DIN rail (IEC/EN/BS 60715).

#### Operational characteristics

- Dissipation per pole: 3...7.5W
- IEC rated insulation voltage  $U_i$ : 440V
- IEC rated impulse voltage  $U_{imp}$ : 4kV
- IEC rated operational voltage  $U_e$ : 230VAC.

#### Certifications and compliance

Certifications obtained: EAC, TÜV-SUD.  
Compliant with standards: IEC/EN/BS 60898-1, IEC/EN/BS 60947-2.

### 1P+N - 6kA 2 modules



P1MB1N...



Order code	Curve	IEC In	IEC Icn	N° of DIN module	Qty per pkg	Wt
		[A]	[kA]	no.	n°	[kg]

Single pole + neutral, thermal and magnetic trip type, C-curve characteristic.

P1MB1NC01	C	1	6	2	6	0.190
P1MB1NC02	C	2	6	2	6	0.190
P1MB1NC04	C	4	6	2	6	0.190
P1MB1NC06	C	6	6	2	6	0.190
P1MB1NC10	C	10	6	2	6	0.190
P1MB1NC16	C	16	6	2	6	0.190
P1MB1NC20	C	20	6	2	6	0.190
P1MB1NC25	C	25	6	2	6	0.190
P1MB1NC32	C	32	6	2	6	0.190
P1MB1NC40	C	40	6	2	6	0.190
P1MB1NC50	C	50	6	2	6	0.190
P1MB1NC63	C	63	6	2	6	0.190

#### General characteristics

- IEC rated current  $I_n$ : 1...63A
- Pole width: 17.5mm / 0.69"
- Contact status with flag indicator
- Trip characteristic: curve type C
- Auxiliary contacts and trip releases mounted on left side
- Fixing on 35mm DIN rail (IEC/EN/BS 60715).

#### Operational characteristics

- Dissipation per pole: 3...13W
- IEC rated insulation voltage  $U_i$ : 440V
- IEC rated impulse voltage  $U_{imp}$ : 4kV
- IEC rated operational voltage  $U_e$ : 230/400VAC.

#### Certifications and compliance

Certifications obtained: EAC.  
Compliant with standards: IEC/EN/BS 60898-1, IEC/EN/BS 60947-2.

### 2P - 10kA (IEC/EN/BS) 2 modules



P1MB2P...

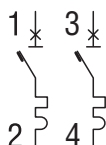

Order code	Curve	IEC In	IEC Icn	N° of DIN module	Qty per pkg	Wt
		[A]	[kA]	n°	n°	[kg]

Two pole, thermal and magnetic trip type, B-curve characteristic.

P1MB2PB01	B	1	10	2	6	0.230
P1MB2PB02	B	2	10	2	6	0.230
P1MB2PB04	B	4	10	2	6	0.230
P1MB2PB06	B	6	10	2	6	0.230
P1MB2PB10	B	10	10	2	6	0.230
P1MB2PB13	B	13	10	2	6	0.230
P1MB2PB16	B	16	10	2	6	0.230
P1MB2PB20	B	20	10	2	6	0.230
P1MB2PB25	B	25	10	2	6	0.230
P1MB2PB32	B	32	10	2	6	0.230
P1MB2PB40	B	40	10	2	6	0.230
P1MB2PB50	B	50	10	2	6	0.230
P1MB2PB63	B	63	10	2	6	0.230

Two pole, thermal and magnetic trip type, C-curve characteristic.

P1MB2PC01	C	1	10	2	6	0.230
P1MB2PC01V6	C	1.6	10	2	6	0.230
P1MB2PC02	C	2	10	2	6	0.230
P1MB2PC03	C	3	10	2	6	0.230
P1MB2PC04	C	4	10	2	6	0.230
P1MB2PC06	C	6	10	2	6	0.230
P1MB2PC08	C	8	10	2	6	0.230
P1MB2PC10	C	10	10	2	6	0.230
P1MB2PC13	C	13	10	2	6	0.230
P1MB2PC16	C	16	10	2	6	0.230
P1MB2PC20	C	20	10	2	6	0.230
P1MB2PC25	C	25	10	2	6	0.230
P1MB2PC32	C	32	10	2	6	0.230
P1MB2PC40	C	40	10	2	6	0.230
P1MB2PC50	C	50	10	2	6	0.230
P1MB2PC63	C	63	10	2	6	0.230

Two pole, thermal and magnetic trip type, D-curve characteristic.

P1MB2PD01	D	1	10	2	6	0.230
P1MB2PD01V6	D	1.6	10	2	6	0.230
P1MB2PD02	D	2	10	2	6	0.230
P1MBDPC03	D	3	10	2	6	0.230
P1MB2PD04	D	4	10	2	6	0.230
P1MB2PD06	D	6	10	2	6	0.230
P1MB2PD08	D	8	10	2	6	0.230
P1MB2PD10	D	10	10	2	6	0.230
P1MB2PD13	D	13	10	2	6	0.230
P1MB2PD16	D	16	10	2	6	0.230
P1MB2PD20	D	20	10	2	6	0.230
P1MB2PD25	D	25	10	2	6	0.230
P1MB2PD32	D	32	10	2	6	0.230
P1MB2PD40	D	40	10	2	6	0.230
P1MB2PD50	D	50	10	2	6	0.230
P1MB2PD63	D	63	10	2	6	0.230

### General characteristics

These devices are used to protect against short circuits and overloads of wiring installations and loads in panel boards, office buildings, stores and similar applications.

Their purpose is circuit protection, circuit isolation and load operation controls. They have characteristics of instantaneous trip defined as follows:

- B-curve: instantaneous trip 3...5 times  $I_n$  for non-inductive or low inductive loads (heating resistors, generators, very long wire lines)
- C-curve: instantaneous trip 5...10 times  $I_n$  for inductive loads (mixed loads, resistive and inductive with low inrush current)
- D-curve: instantaneous trip 10...14 times  $I_n$  for highly inductive loads (loads with high inrush and current such as motors).

Main features include:

- IEC rated current  $I_n$ : 1...63A
- Pole width: 17.5mm / 0.69"
- Contact status with flag indicator
- Trip characteristic: curve type B, C and D
- Auxiliary contacts and trip releases mounted on left side
- Fixing on 35mm DIN rail (IEC/EN/BS 60715).

### Operational characteristics

- Dissipation per pole: 3...13W
- IEC rated insulation voltage  $U_i$ : 440V
- IEC rated impulse voltage  $U_{imp}$ : 4kV
- IEC rated operational voltage  $U_e$ : 230/400VAC
- UL 1077 rated operational voltage: 480VAC
- Short circuit breaking capacity: IEC/EN/BS 10kA - UL 7.5kA 480V.

### Certifications and compliance

Certifications obtained: cURus (E369585); EAC; TÜV-Rheinland.

Compliant with standards: IEC/EN/BS 60898-1, IEC/EN/BS 60947-2, UL 1077, CSA C22.2 n°235.



### 3P - 10kA (IEC/EN/BS) 3 modules



P1MB3P...

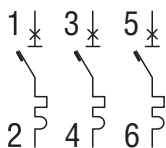

Order code	Curve	IEC In	IEC Icn	N° of DIN module	Qty per pkg	Wt
		[A]	[kA]	n°	n°	[kg]

Three pole, thermal and magnetic trip type, B-curve characteristic.

P1MB3PB01	B	1	10	3	4	0.345
P1MB3PB02	B	2	10	3	4	0.345
P1MB3PB04	B	4	10	3	4	0.345
P1MB3PB06	B	6	10	3	4	0.345
P1MB3PB10	B	10	10	3	4	0.345
P1MB3PB13	B	13	10	3	4	0.345
P1MB3PB16	B	16	10	3	4	0.345
P1MB3PB20	B	20	10	3	4	0.345
P1MB3PB25	B	25	10	3	4	0.345
P1MB3PB32	B	32	10	3	4	0.345
P1MB3PB40	B	40	10	3	4	0.345
P1MB3PB50	B	50	10	3	4	0.345
P1MB3PB63	B	63	10	3	4	0.345

Three pole, thermal and magnetic trip type, C-curve characteristic.

P1MB3PC01	C	1	10	3	4	0.345
P1MB3PC01V6	C	1.6	10	3	4	0.345
P1MB3PC02	C	2	10	3	4	0.345
P1MB3PC03	C	3	10	4	4	0.345
P1MB3PC04	C	4	10	3	4	0.345
P1MB3PC06	C	6	10	3	4	0.345
P1MB3PC08	C	8	10	3	4	0.345
P1MB3PC10	C	10	10	3	4	0.345
P1MB3PC13	C	13	10	3	4	0.345
P1MB3PC16	C	16	10	3	4	0.345
P1MB3PC20	C	20	10	3	4	0.345
P1MB3PC25	C	25	10	3	4	0.345
P1MB3PC32	C	32	10	3	4	0.345
P1MB3PC40	C	40	10	3	4	0.345
P1MB3PC50	C	50	10	3	4	0.345
P1MB3PC63	C	63	10	3	4	0.345

Three pole, thermal and magnetic trip type, D-curve characteristic.

P1MB3PD01	D	1	10	3	4	0.345
P1MB3PD01V6	D	1.6	10	3	4	0.345
P1MB3PD02	D	2	10	3	4	0.345
P1MB3PD03	D	3	10	4	4	0.345
P1MB3PD04	D	4	10	3	4	0.345
P1MB3PD06	D	6	10	3	4	0.345
P1MB3PD08	D	8	10	3	4	0.345
P1MB3PD10	D	10	10	3	4	0.345
P1MB3PD13	D	13	10	3	4	0.345
P1MB3PD16	D	16	10	3	4	0.345
P1MB3PD20	D	20	10	3	4	0.345
P1MB3PD25	D	25	10	3	4	0.345
P1MB3PD32	D	32	10	3	4	0.345
P1MB3PD40	D	40	10	3	4	0.345
P1MB3PD50	D	50	10	3	4	0.345
P1MB3PD63	D	63	10	3	4	0.345

#### General characteristics

These devices are used to protect against short circuits and overloads of wiring installations and loads in panel boards, office buildings, stores and similar applications. Their purpose is circuit protection, circuit isolation and load operation controls. They have characteristics of instantaneous trip defined as follows:

- B-curve: instantaneous trip 3...5 times  $I_n$  for non-inductive or low inductive loads (heating resistors, generators, very long wire lines)
- C-curve: instantaneous trip 5...10 times  $I_n$  for inductive loads (mixed loads, resistive and inductive with low inrush current)
- D-curve: instantaneous trip 10...14 times  $I_n$  for highly inductive loads (loads with high inrush and current such as motors).

Main features include:

- IEC rated current  $I_n$ : 1...63A
- Pole width: 17.5mm / 0.69"
- Contact status with flag indicator
- Trip characteristic: curve type B, C and D
- Auxiliary contacts and trip releases mounted on left side
- Fixing on 35mm DIN rail (IEC/EN/BS 60715).

#### Operational characteristics

- Dissipation per pole: 3...13W
- IEC rated insulation voltage  $U_i$ : 440V
- IEC rated impulse voltage  $U_{imp}$ : 4kV
- IEC rated operational voltage  $U_e$ : 230/400VAC
- UL 1077 rated operational voltage: 480VAC
- Short circuit breaking capacity: IEC/EN/BS 10kA - UL 7.5kA 480V.

#### Certifications and compliance

Certifications obtained: cURus (E369585); EAC; TÜV-Rheinland.

Compliant with standards: IEC/EN/BS 60898-1, IEC/EN/BS 60947-2, UL 1077, CSA C22.2 n°235.

### 4P - 10kA (IEC/EN/BS) 4 modules



P1MB4P...

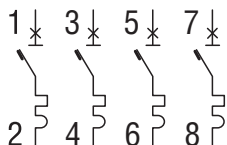

Order code	Curve	IEC In	IEC Icn	N° of DIN module	Qty per pkg	Wt
		[A]	[kA]	n°	n°	[kg]

Four pole, thermal and magnetic trip type, B-curve characteristic.

P1MB4PB01	B	1	10	4	3	0.460
P1MB4PB02	B	2	10	4	3	0.460
P1MB4PB04	B	4	10	4	3	0.460
P1MB4PB06	B	6	10	4	3	0.460
P1MB4PB10	B	10	10	4	3	0.460
P1MB4PB13	B	13	10	4	3	0.460
P1MB4PB16	B	16	10	4	3	0.460
P1MB4PB20	B	20	10	4	3	0.460
P1MB4PB25	B	25	10	4	3	0.460
P1MB4PB32	B	32	10	4	3	0.460
P1MB4PB40	B	40	10	4	3	0.460
P1MB4PB50	B	50	10	4	3	0.460
P1MB4PB63	B	63	10	4	3	0.460

Four pole, thermal and magnetic trip type, C-curve characteristic.

P1MB4PC01	C	1	10	4	3	0.460
P1MB4PC02	C	2	10	4	3	0.460
P1MB4PC04	C	4	10	4	3	0.460
P1MB4PC06	C	6	10	4	3	0.460
P1MB4PC10	C	10	10	4	3	0.460
P1MB4PC13	C	13	10	4	3	0.460
P1MB4PC16	C	16	10	4	3	0.460
P1MB4PC20	C	20	10	4	3	0.460
P1MB4PC25	C	25	10	4	3	0.460
P1MB4PC32	C	32	10	4	3	0.460
P1MB4PC40	C	40	10	4	3	0.460
P1MB4PC50	C	50	10	4	3	0.460
P1MB4PC63	C	63	10	4	3	0.460

Four pole, thermal and magnetic trip type, D-curve characteristic.

P1MB4PD01	D	1	10	4	3	0.460
P1MB4PD02	D	2	10	4	3	0.460
P1MB4PD04	D	4	10	4	3	0.460
P1MB4PD06	D	6	10	4	3	0.460
P1MB4PD10	D	10	10	4	3	0.460
P1MB4PD13	D	13	10	4	3	0.460
P1MB4PD16	D	16	10	4	3	0.460
P1MB4PD20	D	20	10	4	3	0.460
P1MB4PD25	D	25	10	4	3	0.460
P1MB4PD32	D	32	10	4	3	0.460
P1MB4PD40	D	40	10	4	3	0.460
P1MB4PD50	D	50	10	4	3	0.460
P1MB4PD63	D	63	10	4	3	0.460

### General characteristics

These devices are used to protect against short circuits and overloads of wiring installations and loads in panel boards, office buildings, stores and similar applications.

Their purpose is circuit protection, circuit isolation and load operation controls. They have characteristics of instantaneous trip defined as follows:

- B-curve: instantaneous trip 3...5 times I<sub>n</sub> for non-inductive or low inductive loads (heating resistors, generators, very long wire lines)
- C-curve: instantaneous trip 5...10 times I<sub>n</sub> for inductive loads (mixed loads, resistive and inductive with low inrush current)
- D-curve: instantaneous trip 10...14 times I<sub>n</sub> for highly inductive loads (loads with high inrush and current such as motors).

Main features include:

- IEC rated current I<sub>n</sub>: 1...63A
- Pole width: 17.5mm / 0.69"
- Contact status with flag indicator
- Trip characteristic: curve type B, C and D
- Auxiliary contacts and trip releases mounted on left side
- Fixing on 35mm DIN rail (IEC/EN/BS 60715).

### Operational characteristics

- Dissipation per pole: 3...13W
- IEC rated insulation voltage U<sub>i</sub>: 440V
- IEC rated impulse voltage U<sub>imp</sub>: 4kV
- IEC rated operational voltage U<sub>e</sub>: 230/400VAC
- UL 1077 rated operational voltage: 480VAC
- Short circuit breaking capacity: IEC/EN/BS 10kA - UL 7.5kA 480V.

### Certifications and compliance

Certifications obtained: cURus (E369585); EAC; TÜV-Rheinland.

Compliant with standards: IEC/EN/BS 60898-1, IEC/EN/BS 60947-2, UL 1077, CSA C22.2 n°235.

### 1P - 10kA (IEC/EN/BS) 1 module



P1MB...1P...



Order code	Curve	IEC In	Rat. volt.	N° of DIN mod.	Qty per pkg	Wt
		[A]	[V]	n°	n°	[kg]

One pole, thermal and magnetic trip type, C-curve characteristic.

P1MBUH1PC01	C	1	277	1	12	0.133
P1MBUH1PC01V6	C	1.6	277	1	12	0.133
P1MBUH1PC02	C	2	277	1	12	0.133
P1MBUH1PC03	C	3	277	1	12	0.133
P1MBUH1PC04	C	4	277	1	12	0.133
P1MBUH1PC05	C	5	277	1	12	0.133
P1MBUH1PC06	C	6	277	1	12	0.133
P1MBUH1PC07	C	7	277	1	12	0.133
P1MBUH1PC08	C	8	277	1	12	0.133
P1MBUH1PC10	C	10	277	1	12	0.133
P1MBUH1PC12	C	12	277	1	12	0.133
P1MBUH1PC13	C	13	277	1	12	0.133
P1MBUH1PC15	C	15	277	1	12	0.133
P1MBUH1PC16	C	16	277	1	12	0.133
P1MBUH1PC20	C	20	277	1	12	0.133
P1MBUH1PC25	C	25	277	1	12	0.133
P1MBUH1PC30	C	30	277	1	12	0.133
P1MBUH1PC32	C	32	277	1	12	0.133
P1MBUL1PC35	C	35	120	1	12	0.133
P1MBUL1PC40	C	40	120	1	12	0.133
P1MBUL1PC50	C	50	120	1	12	0.133
P1MBUL1PC60	C	60	120	1	12	0.133
P1MBUL1PC63	C	63	120	1	12	0.133

One pole, thermal and magnetic trip type, D-curve characteristic.

P1MBUH1PD01	D	1	277	1	12	0.133
P1MBUH1PD01V6	D	1.6	277	1	12	0.133
P1MBUH1PD02	D	2	277	1	12	0.133
P1MBUH1PD03	D	3	277	1	12	0.133
P1MBUH1PD04	D	4	277	1	12	0.133
P1MBUH1PD05	D	5	277	1	12	0.133
P1MBUH1PD06	D	6	277	1	12	0.133
P1MBUH1PD07	D	7	277	1	12	0.133
P1MBUH1PD08	D	8	277	1	12	0.133
P1MBUH1PD10	D	10	277	1	12	0.133
P1MBUH1PD12	D	12	277	1	12	0.133
P1MBUH1PD13	D	13	277	1	12	0.133
P1MBUH1PD15	D	15	277	1	12	0.133
P1MBUH1PD16	D	16	277	1	12	0.133
P1MBUH1PD20	D	20	277	1	12	0.133
P1MBUH1PD25	D	25	277	1	12	0.133
P1MBUH1PD30	D	30	277	1	12	0.133
P1MBUH1PD32	D	32	277	1	12	0.133
P1MBUL1PD35	D	35	120	1	12	0.133
P1MBUL1PD40	D	40	120	1	12	0.133
P1MBUL1PD50	D	50	120	1	12	0.133
P1MBUL1PD60	D	60	120	1	12	0.133
P1MBUL1PD63	D	63	120	1	12	0.133

### General characteristics

These devices comply with the UL 489 standard, mostly used in the North American markets. They are designed to protect feeder circuits, the part of the system from the network supply point to the protection device for a branch circuit. They can also be used on the international market thanks to compliance with the IEC/EN/BS 60947-2 standard.

They have characteristics of tripping instantaneously defined as follows:

- C-curve: instantaneous trip 5...10 times  $I_n$  for inductive loads (mixed loads, resistive and inductive with low inrush current)
- D-curve: instantaneous trip 10...14 times  $I_n$  for highly inductive loads (loads with high inrush and current such as motors).

### Operational characteristics

- Dissipation per pole: 3...13W
- Rated voltage 1...32A: 277V (UL 489)
- Rated voltage 35...63A: 120V (UL 489)
- Rated insulation voltage  $U_i$ : 440V (IEC/EN/BS 60947-2)
- Rated impulse voltage  $U_{imp}$ : 4kV (IEC/EN/BS 60947-2)
- Rated operational voltage  $U_e$ : 230/400VAC (IEC/EN/BS 60947-2)
- DC operational voltage: 60V
- Short circuit breaking capacity: IEC/EN/BS 10kA - UL 10kA.

### Certifications and compliance

Certifications obtained: cULus (E481234); EAC.  
Compliant with standards: UL 489, IEC/EN/BS 60947-2.



### 2P - 10kA (IEC/EN/BS) 2 modules



P1MB...2P...

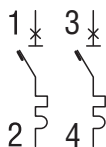

Order code	Curve	IEC In	Rated voltage	N° of DIN mod.	Qty per pkg	Wt
		[A]	[V]	n°	n°	[kg]

Two pole, thermal and magnetic trip type, C-curve characteristic.

P1MBUH2PC01	C	1	480Y/277	2	6	0.255
P1MBUH2PC01V6	C	1.6	480Y/277	2	6	0.255
P1MBUH2PC02	C	2	480Y/277	2	6	0.255
P1MBUH2PC03	C	3	480Y/277	2	6	0.255
P1MBUH2PC04	C	4	480Y/277	2	6	0.255
P1MBUH2PC05	C	5	480Y/277	2	6	0.255
P1MBUH2PC06	C	6	480Y/277	2	6	0.255
P1MBUH2PC07	C	7	480Y/277	2	6	0.255
P1MBUH2PC08	C	8	480Y/277	2	6	0.255
P1MBUH2PC10	C	10	480Y/277	2	6	0.255
P1MBUH2PC12	C	12	480Y/277	2	6	0.255
P1MBUH2PC13	C	13	480Y/277	2	6	0.255
P1MBUH2PC15	C	15	480Y/277	2	6	0.255
P1MBUH2PC16	C	16	480Y/277	2	6	0.255
P1MBUH2PC20	C	20	480Y/277	2	6	0.255
P1MBUH2PC25	C	25	480Y/277	2	6	0.255
P1MBUH2PC30	C	30	480Y/277	2	6	0.255
P1MBUH2PC32	C	32	480Y/277	2	6	0.255
P1MBUL2PC35	C	35	240	2	6	0.255
P1MBUL2PC40	C	40	240	2	6	0.255
P1MBUL2PC50	C	50	240	2	6	0.255
P1MBUL2PC60	C	60	240	2	6	0.255
P1MBUL2PC63	C	63	240	2	6	0.255

Two pole, thermal and magnetic trip type, D-curve characteristic.

P1MBUH2PD01	D	1	480Y/277	2	6	0.255
P1MBUH2PD01V6	D	1.6	480Y/277	2	6	0.255
P1MBUH2PD02	D	2	480Y/277	2	6	0.255
P1MBUH2PD03	D	3	480Y/277	2	6	0.255
P1MBUH2PD04	D	4	480Y/277	2	6	0.255
P1MBUH2PD05	D	5	480Y/277	2	6	0.255
P1MBUH2PD06	D	6	480Y/277	2	6	0.255
P1MBUH2PD07	D	7	480Y/277	2	6	0.255
P1MBUH2PD08	D	8	480Y/277	2	6	0.255
P1MBUH2PD10	D	10	480Y/277	2	6	0.255
P1MBUH2PD12	D	12	480Y/277	2	6	0.255
P1MBUH2PD13	D	13	480Y/277	2	6	0.255
P1MBUH2PD15	D	15	480Y/277	2	6	0.255
P1MBUH2PD16	D	16	480Y/277	2	6	0.255
P1MBUH2PD20	D	20	480Y/277	2	6	0.255
P1MBUH2PD25	D	25	480Y/277	2	6	0.255
P1MBUH2PD30	D	30	480Y/277	2	6	0.255
P1MBUH2PD32	D	32	480Y/277	2	6	0.255
P1MBUL2PD35	D	35	240	2	6	0.255
P1MBUL2PD40	D	40	240	2	6	0.255
P1MBUL2PD50	D	50	240	2	6	0.255
P1MBUL2PD60	D	60	240	2	6	0.255
P1MBUL2PD63	D	63	240	2	6	0.255

### General characteristics

These devices comply with the UL 489 standard, mostly used in the North American markets. They are designed to protect feeder circuits, the part of the system from the network supply point to the protection device for a branch circuit. They can in any case be used on the international market thanks to compliance with the IEC/EN/BS 60947-2 standard as well.

They have characteristics of tripping instantaneously defined as follows:

- C-curve: instantaneous trip 5...10 times In for inductive loads (mixed loads, resistive and inductive with low inrush current)
- D-curve: instantaneous trip 10...14 times In for highly inductive loads (loads with high inrush and current such as motors).

### Operational characteristics

- Rated voltage 1...32A: 480Y/277V (UL 489)
- Rated voltage 35...63A: 240V (UL 489)
- Rated insulation voltage Ui: 440V (IEC/EN/BS 60947-2)
- Rated impulse voltage Uimp: 4kV (IEC/EN/BS 60947-2)
- Rated operational voltage Ue: 230/400VAC (IEC/EN/BS 60947-2)
- DC operational voltage: 125V
- Short circuit breaking capacity: IEC/EN/BS 10kA - UL 10kA.

### Certifications and compliance

Certifications obtained: cULus (E481234); EAC.  
Compliant with standards: UL 489, IEC/EN/BS 60947-2.

### 3P - 10kA (IEC/EN/BS) 3 modules



P1MB...3P...

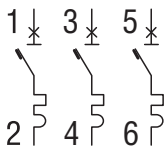

Order code	Curve	IEC In	Rated voltage	N° of DIN mod.	Qty per pkg	Wt
		[A]	[V]	n°	n°	[kg]

Three pole, thermal and magnetic trip type, C-curve characteristic.

P1MBUH3PC01	C	1	480Y/277	3	4	0.388
P1MBUH3PC01V6	C	1.6	480Y/277	3	4	0.388
P1MBUH3PC02	C	2	480Y/277	3	4	0.388
P1MBUH3PC03	C	3	480Y/277	3	4	0.388
P1MBUH3PC04	C	4	480Y/277	3	4	0.388
P1MBUH3PC05	C	5	480Y/277	3	4	0.388
P1MBUH3PC06	C	6	480Y/277	3	4	0.388
P1MBUH3PC07	C	7	480Y/277	3	4	0.388
P1MBUH3PC08	C	8	480Y/277	3	4	0.388
P1MBUH3PC10	C	10	480Y/277	3	4	0.388
P1MBUH3PC12	C	12	480Y/277	3	4	0.388
P1MBUH3PC13	C	13	480Y/277	3	4	0.388
P1MBUH3PC15	C	15	480Y/277	3	4	0.388
P1MBUH3PC16	C	16	480Y/277	3	4	0.388
P1MBUH3PC20	C	20	480Y/277	3	4	0.388
P1MBUH3PC25	C	25	480Y/277	3	4	0.388
P1MBUH3PC30	C	30	480Y/277	3	4	0.388
P1MBUH3PC32	C	32	480Y/277	3	4	0.388
P1MBUL3PC35	C	35	240	3	4	0.388
P1MBUL3PC40	C	40	240	3	4	0.388
P1MBUL3PC50	C	50	240	3	4	0.388
P1MBUL3PC60	C	60	240	3	4	0.388
P1MBUL3PC63	C	63	240	3	4	0.388

Three pole, thermal and magnetic trip type, D-curve characteristic.

P1MBUH3PD01	D	1	480Y/277	3	4	0.388
P1MBUH3PD01V6	D	1.6	480Y/277	3	4	0.388
P1MBUH3PD02	D	2	480Y/277	3	4	0.388
P1MBUH3PD03	D	3	480Y/277	3	4	0.388
P1MBUH3PD04	D	4	480Y/277	3	4	0.388
P1MBUH3PD05	D	5	480Y/277	3	4	0.388
P1MBUH3PD06	D	6	480Y/277	3	4	0.388
P1MBUH3PD07	D	7	480Y/277	3	4	0.388
P1MBUH3PD08	D	8	480Y/277	3	4	0.388
P1MBUH3PD10	D	10	480Y/277	3	4	0.388
P1MBUH3PD12	D	12	480Y/277	3	4	0.388
P1MBUH3PD13	D	13	480Y/277	3	4	0.388
P1MBUH3PD15	D	15	480Y/277	3	4	0.388
P1MBUH3PD16	D	16	480Y/277	3	4	0.388
P1MBUH3PD20	D	20	480Y/277	3	4	0.388
P1MBUH3PD25	D	25	480Y/277	3	4	0.388
P1MBUH3PD30	D	30	480Y/277	3	4	0.388
P1MBUH3PD32	D	32	480Y/277	3	4	0.388
P1MBUL3PD35	D	35	240	3	4	0.388
P1MBUL3PD40	D	40	240	3	4	0.388
P1MBUL3PD50	D	50	240	3	4	0.388
P1MBUL3PD60	D	60	240	3	4	0.388
P1MBUL3PD63	D	63	240	3	4	0.388

#### General characteristics

These devices comply with the UL 489 standard, mostly used in the North American markets. They are designed to protect feeder circuits, the part of the system from the network supply point to the protection device for a branch circuit. They can also be used on the international market thanks to compliance with the IEC/EN/BS 60947-2 standard.

They have characteristics of tripping instantaneously defined as follows:

- C-curve: instantaneous trip 5...10 times In for inductive loads (mixed loads, resistive and inductive with low inrush current)
- D-curve: instantaneous trip 10...14 times In for highly inductive loads (loads with high inrush and current such as motors).

#### Operational characteristics

- Rated voltage 1...32A: 480Y/277V (UL 489)
- Rated voltage 35...63A: 240V (UL 489)
- Rated insulation voltage Ui: 440V (IEC/EN/BS 60947-2)
- Rated impulse voltage Uimp: 4kV (IEC/EN/BS 60947-2)
- Rated operational voltage Ue: 230/400VAC (IEC/EN/BS 60947-2)
- DC operational voltage: 125V
- Short circuit breaking capacity: IEC/EN/BS 10kA - UL 10kA.

#### Certifications and compliance

Certifications obtained: cULus (E481234); EAC. Compliant with standards: UL 489, IEC/EN/BS 60947-2.

# 14 Miniature and residual circuit breakers

Miniature circuit breakers 80...125A, UL 1077

## 1P, 2P, 3P and 4P - 10kA (IEC/EN/BS)



P2MB1P...



P2MB2P...

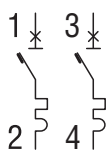

P2MB3P...

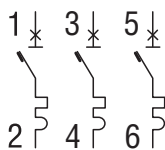

P2MB4P...

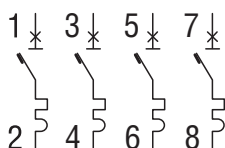

Order code	Curve	IEC In	IEC Icn	N° of DIN module	Qty per pkg	Wt
		[A]	[kA]	no.	no.	[kg]

One pole, thermal and magnetic trip type, C-curve characteristic.

P2MB1PC080	C	80	10 <sup>Ⓢ</sup>	1.5	9	0.166
P2MB1PC100	C	100	10 <sup>Ⓢ</sup>	1.5	9	0.166
P2MB1PC125	C	125	10 <sup>Ⓢ</sup>	1.5	9	0.166

Two pole, thermal and magnetic trip type, C-curve characteristic.

P2MB2PC080	C	80	10	3	4	0.340
P2MB2PC100	C	100	10	3	4	0.340
P2MB2PC125	C	125	10	3	4	0.340

Three pole, thermal and magnetic trip type, C-curve characteristic.

P2MB3PC080	C	80	10	4.5	3	0.510
P2MB3PC100	C	100	10	4.5	3	0.510
P2MB3PC125	C	125	10	4.5	3	0.510

Four pole, thermal and magnetic trip type, C-curve characteristic.

P2MB4PC080	C	80	10	6	2	0.680
P2MB4PC100	C	100	10	6	2	0.680
P2MB4PC125	C	125	10	6	2	0.680

Three pole, thermal and magnetic trip type, D-curve characteristic.

P2MB3PD080	D	80	10	4.5	3	0.510
P2MB3PD100	D	100	10	4.5	3	0.510
P2MB3PD125	D	125	10	4.5	3	0.510

Four pole, thermal and magnetic trip type, D-curve characteristic.

P2MB4PD080	D	80	10	6	2	0.510
P2MB4PD100	D	100	10	6	2	0.510
P2MB4PD125	D	125	10	6	2	0.510

<sup>Ⓢ</sup> Icn at 230V.

### General characteristics

These devices are used to protect against short circuits and overloads of wiring installations and loads in panel boards, office buildings, stores and similar applications.

Their purpose is circuit protection, circuit isolation and load operation controls. They have characteristics of instantaneous trip defined as follows:

- C-curve: instantaneous trip 5...10 times In for inductive loads (mixed loads, resistive and inductive with low inrush current)
- D-curve: instantaneous trip 10...14 times In for highly inductive loads (loads with high inrush and current such as motors).

Main features include:

- IEC rated current In: 80...125A
- Pole width: 27mm / 1.06"
- Contact status with flag indicator
- Trip characteristic: curve type C and D
- Fixing on 35mm DIN rail (IEC/EN/BS 60715).

### Operational characteristics

- Dissipation per pole: 15...20W
- IEC rated insulation voltage Ui: 400V
- IEC rated impulse voltage Uimp: 4kV
- IEC rated operational voltage Ue: 230/400VAC (230VAC 1P version)
- Short circuit breaking capacity: IEC/EN/BS 10kA - UL 5kA 240V (1P) - 5kA 480V (2-3-4P).

### Certifications and compliance

Certifications obtained: cURus (E369585); EAC; TÜV-Rheinland.

Compliant with standards: IEC/EN/BS 60898-1, IEC/EN/BS 60947-2, UL 1077, CSA C22.2 n°235.

### Add-on blocks for miniature circuit breakers 1...63A



P1X1011

P1X16230

Order code	Description	Qty per MCB	Qty per pkg	Wt
		n°	n°	[kg]
Auxiliary contact.				
<b>P1X1011</b>	1 changeover contact for P1MB...	1	10	0.040
<b>P1X1011UH</b>	1 changeover contact for P1MBU...	1	10	0.040
Indicator contact for thermal-magnetic trip.				
<b>P1X1311</b>	1 changeover contact	1	10	0.040
Undervoltage trip release.				
<b>P1X14230</b>	230V 50/60Hz	1	8	0.070
Shunt trip release.				
<b>P1X16230</b>	110...415V 50/60Hz	1	8	0.070

Not suitable for P1MBU...

#### General characteristics

- Auxiliary and indicator contact width: 9mm/0.35" (0.5 module)
- Undervoltage and shunt trip release width: 18mm/0.71" (1 module)
- Maximum combination: 3 add-on blocks on MCB left side only of which 1 undervoltage or shunt release directly on MCB side and then 2 contacts of which 1 auxiliary and 1 indicator.

#### Operational characteristics

- IEC rated impulse voltage Uimp: 4kV
- IEC rated operational current in AC: 6A 230V; 3A 400V (auxiliary contacts).

#### Certifications and compliance

Certifications obtained: EAC, cURus (excluding P1X14230), UL (only P1X14230)  
Compliant with standards: IEC/EN/BS 60947-5-1, CSA C22.2 n° 5.

### Add-on blocks for miniature circuit breakers 80...125A



P2X1311

P2X16230

Order code	Description	Qty per MCB	Qty per pkg	Wt
		n°	n°	[kg]
Auxiliary contact.				
<b>P2X1011</b>	1 changeover contact	1	10	0.040
Indicator contact for thermal-magnetic trip.				
<b>P2X1311</b>	1 changeover contact	1	10	0.040
Shunt trip release.				
<b>P2X16230</b>	110...415V 50/60Hz	1	8	0.070

#### General characteristics

- Auxiliary and indicator contact width: 9mm/0.35" (0.5 module)
- Shunt trip release width: 17.5mm/0.69" (1 module)
- Maximum combination: 3 add-on blocks on MCB sides of which 1 undervoltage or shunt release on MCB right side and 2 contacts on the left of which 1 auxiliary and 1 indicator.

#### Operational characteristics

- IEC rated insulation voltage Ui: 500V
- Rated impulse voltage Uimp: 4kV
- Rated operational current in AC: 6A 230V; 3A 400V (auxiliary contacts).

#### Certifications and compliance

Certifications obtained: EAC.  
Compliant with standards: IEC/EN/BS 60947-5-1.

### Accessories for miniature circuit breakers

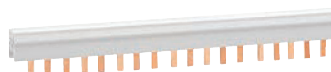

P1X9033



P1X9133



P1X9201

P1X9210

P1X9202



P1X1810

P2X1810

① Suitable for P1MB...  
Not suitable for P1MBU...

Order code	Description	Qty per pkg	Wt [kg]
		n°	[kg]
P1X9031①	Single-pole supply busbar	10	0.160
P1X9032①	Two-pole supply busbar	10	0.320
P1X9033①	Three-pole supply busbar	10	0.474
P1X9034①	Four-pole supply busbar	10	0.600
P1X9130①	Kit of 5 isolating covers for unused busbar terminals	10	0.030
P1X9131①	End cap for P1X9031	50	0.001
P1X9132①	End cap for P1X9032	50	0.001
P1X9133①	End cap for P1X9033	50	0.001
P1X9134①	End cap for P1X9034	50	0.001
P1X9201①	Single-pole terminal for busbar supply; conductor cross section 25mm <sup>2</sup> max.	25	0.010
P1X9210①	1-pole terminal for supplying busbar; conductor cross section 25mm <sup>2</sup> max.; left entry	25	0.010
P1X9202①	Single-pole terminal for busbar supply; conductor cross section 50mm <sup>2</sup> max.	25	0.022
P1X1810	Padlockable attachment for breaker control lever P1MB...	10	0.001
P2X1810	Padlockable attachment for breaker control lever P2MB...	10	0.002

### General and operational characteristics

#### SINGLE-POLE SUPPLY BUSBAR

- Rated operational voltage U<sub>e</sub>: 1000V
- Central point of power supply: 100A max.
- Side point of power supply: 63A max.
- Spacing: 17.8mm/0.70"
- Busbar section: 10mm<sup>2</sup>
- For paralleling connection
- For 57 modules, 1000mm/39.37" long (57 1P breakers).

#### TWO-POLE, THREE-POLE AND FOUR-POLE SUPPLY BUSBARS

- Rated operational voltage U<sub>e</sub>: 690V
- Central point of power supply: 100A max.
- Side point of power supply: 63A max.
- Spacing: 17.8mm/0.70"
- Busbar section: 10mm<sup>2</sup>
- For paralleling connection
- Two-pole: for 56 modules, 1000mm/39.37" long (28 2P breakers)
- Three-pole: for 57 modules, 1012mm/39.84" long (19 3P breakers)
- Four-pole: for 56 modules, 1000mm/39.37" long (14 4P breakers).

#### PADLOCKABLE ATTACHMENT

- Max. padlock diameter 5mm/0.20"
- Padlockable in ON and OFF
- One can be fitted for each pole of the breaker.

### UL approved supply busbar



3P18L57S0U50



802150S



802180



ULC...



BRU3V



802307

Order code	Description	Qty per pkg	Wt [kg]
		n°	[kg]
Power bars for UL 1077 thermal-magnetic circuit breakers, type P1MB...			
1P18K57S0U50	Single-pole supply busbar	10	0.160
2P18L56S0U50	Two-pole supply busbar	10	0.320
3P18L57S0U50	Three-pole supply busbar	10	0.474
BRB5W	Kit of 5 insulating caps for unused bar terminals	10	0.030
A69	End cap for 1P18K57S0U50	50	0.001
A7	End cap for 2P18L56S0U50 and 3P18L57S0U50	50	0.001
802150S	Single-pole terminal block to supply busbar 1P18K57S0U50; conductor section 10 to 1 AWG	25	0.030
802180	Single-pole terminal block to supply busbar 2P18L56S0U50 and 3P18L57S0U50; conductor section 10 to 1 AWG	10	0.030
Power bars for UL 489 thermal-magnetic circuit breakers, type P1MBU...			
ULC157A18A	Single pole power bar	10	0.160
ULC256A18A	Two pole power bar	10	0.320
ULC357A18A	Three pole power bar	10	0.474
BRU3V	Kit of 3 insulating caps for unused bar terminals	10	0.022
A68	End cap for all ULC... type bars	50	0.001
802307	Single-pole terminal block to power bars; conductor section 14 to 2 AWG	10	0.030

### Main features

UL approved power bars are divided into two groups:

- Bars for UL 1077 approved thermal-magnetic circuit breakers;
- Bars for UL 489 approved thermal-magnetic circuit breaker bars.

Both models are supplied 1000mm/39.37" long and can be cut to the desired length. This feature makes it easy to adapt to any combination of installed thermal-magnetic circuit breakers. Special end caps must be applied at the points where the bars are cut, to ensure IP20 protection and to comply with UL standards.

### Operational characteristics

#### POWER BARS FOR UL APPROVED THERMAL-MAGNETIC CIRCUIT BREAKERS

- Maximum rated AC voltage: 600V
- Central power point: 160A max
- Side point for power supply: 80A max
- Spacing: 17.8mm/0.70"
- Bar section: 18mm<sup>2</sup>
- For parallel connection
- Single pole: for 57 modules, 1000mm/39.37" long (57 1P switches)
- Two pole: for 56 modules, 1000mm/39.37" long (28 2P switches)
- Three pole: for 57 modules, 1012mm/39.84" long (19 3P switches).

### Certifications

UL 508 for P18K57... bars (for use with UL 1077 approved thermal-magnetic circuit breakers).  
UL 489 for UL... bars (for use with UL 489 approved thermal-magnetic circuit breakers).



# 14 Miniature and residual circuit breakers

Switch disconnectors.  
Residual blocks

## Switch disconnectors



P1MS1P...



P1MS2P...



P1MS3P...



P1MS4P...

**new**

Order code	Ie [A]	N° of DIN module	Qty per pkg	Wt [kg]
Modular switch disconnectors - 1P.				
P1MS1P032	32	1	12	0.083
P1MS1P040	40	1	12	0.083
P1MS1P063	63	1	12	0.083
P1MS1P100	100	1	12	0.083
P1MS1P125	125	1	12	0.083
Modular switch disconnectors - 2P.				
P1MS2P032	32	2	6	0.170
P1MS2P040	40	2	6	0.170
P1MS2P063	63	2	6	0.170
P1MS2P100	100	2	6	0.170
P1MS2P125	125	2	6	0.170
Modular switch disconnectors - 3P.				
P1MS3P032	32	3	4	0.250
P1MS3P040	40	3	4	0.250
P1MS3P063	63	3	4	0.250
P1MS3P100	100	3	4	0.250
P1MS3P125	125	3	4	0.250
Modular switch disconnectors - 4P.				
P1MS4P032	32	4	3	0.330
P1MS4P040	40	4	3	0.330
P1MS4P063	63	4	3	0.330
P1MS4P100	100	4	3	0.330
P1MS4P125	125	4	3	0.330

### General characteristics

These devices are mainly used for disconnection and insulation of power lines and systems. They can also be used to switch various types of resistive and inductive loads.

Main features include:

- IEC rated current I<sub>n</sub>: 32...125A
- Pole width: 17.5mm / 0.69"
- Clear contact status indication
- Wide terminals for easy wiring
- Auxiliary contacts can be mounted on left side and padlockable attachment
- Fixing on 35mm DIN rail (IEC/EN/BS 60715).

### Operational characteristics

- Utilisation category: AC-22A
- IEC rated insulation voltage U<sub>i</sub>: 1000V
- IEC rated impulse voltage U<sub>imp</sub>: 4kV
- IEC rated operational voltage U<sub>e</sub>: 1P 230...240V; 2P, 3P, 4P 400...440V
- IEC rated short-time withstand current I<sub>cw</sub>: 12xI<sub>e</sub> (for 1 second).

### Certifications and compliance

Certifications obtained: TÜV-Rheinland, EAC.  
Compliant with standards: IEC/EN/BS 60947-3.

## Add-on blocks for switch disconnectors P1MS...



P1X1011S



P1X1810

Order code	Description	Qty per breaker	Qty per pkg	Wt [kg]
P1X1011S	Auxiliary contact, 1 changeover contact	1	1	0.040
P1X1810	Padlockable attachment for breaker control lever P1MS...	1	10	0.001

## Residual blocks



P1RA2P...



P1RA3P...

Order code	Type	IEC In [A]	IEC IΔn [mA]	N° of DIN module	Qty per pkg	Wt [kg]
Residual blocks - 2P - type A.						
P1RA2P40A030	A	40	30	2	1	0.160
P1RA2P40A300	A	40	300	2	1	0.160
P1RA2P63A030	A	63	30	2	1	0.160
P1RA2P63A300	A	63	300	2	1	0.160
Residual blocks - 3P - type A.						
P1RA3P40A030	A	40	30	3.5	1	0.205
P1RA3P40A300	A	40	300	3.5	1	0.205
P1RA3P63A030	A	63	30	3.5	1	0.205
P1RA3P63A300	A	63	300	3.5	1	0.205
Residual blocks - 4P - type A.						
P1RA4P40A030	A	40	30	3.5	1	0.230
P1RA4P40A300	A	40	300	3.5	1	0.230
P1RA4P63A030	A	63	30	3.5	1	0.230
P1RA4P63A300	A	63	300	3.5	1	0.230

### General characteristics

These devices are intended for the protection of people against indirect contact (electric shock) and of installations against fire hazards due to a persistent earth/ground fault current.

They snap onto the P1MB... series thermal-magnetic circuit breakers; this combination forms a single device to protect people, protect against fire and protect lines.

### Operational characteristics

- IEC rated insulation voltage U<sub>i</sub>: 400V
- IEC rated impulse voltage U<sub>imp</sub>: 4kV
- IEC rated frequency: 50/60Hz
- IEC rated operational voltage U<sub>e</sub>: 230/400V
- IEC rated residual current for tripping IΔn: 30mA; 300mA
- Dissipation per pole: 1.6W (40A), 2.7W (63A).

### Certifications and compliance

Compliance with standards: IEC/EN/BS 61009-1.  
Certifications obtained: TÜV-SUD, EAC.

### Residual current operated circuit breakers (RCCB)



P1RD2P...

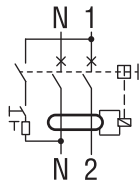

P1RD4P...

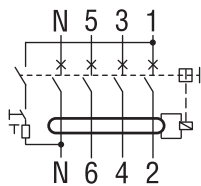

P1RC4PB...

**new**

Order code	Type	IEC In	IEC IΔn	N° of DIN module	Qty per pkg	Wt
		[A]	[mA]	n°	n°	[kg]

Two pole RCCB type AC.						
P1RD2P25AC030	AC	25	30	2	1	0.185
P1RD2P25AC300	AC	25	300	2	1	0.185
P1RD2P40AC030	AC	40	30	2	1	0.185
P1RD2P40AC300	AC	40	300	2	1	0.185
P1RD2P63AC030	AC	63	30	2	1	0.185
P1RD2P63AC300	AC	63	300	2	1	0.185

Two pole RCCB type A.						
P1RD2P25A030	A	25	30	2	1	0.185
P1RD2P25A300	A	25	300	2	1	0.185
P1RD2P40A030	A	40	30	2	1	0.185
P1RD2P40A300	A	40	300	2	1	0.185
P1RD2P63A030	A	63	30	2	1	0.185
P1RD2P63A300	A	63	300	2	1	0.185

Four pole RCCB type AC.						
P1RD4P25AC030	AC	25	30	4	1	0.326
P1RD4P25AC300	AC	25	300	4	1	0.326
P1RD4P40AC030	AC	40	30	4	1	0.326
P1RD4P40AC300	AC	40	300	4	1	0.326
P1RD4P63AC030	AC	63	30	4	1	0.326
P1RD4P63AC300	AC	63	300	4	1	0.326

Four pole RCCB type A.						
P1RD4P25A030	A	25	30	4	1	0.326
P1RD4P25A300	A	25	300	4	1	0.326
P1RD4P40A030	A	40	30	4	1	0.326
P1RD4P40A300	A	40	300	4	1	0.326
P1RD4P63A030	A	63	30	4	1	0.326
P1RD4P63A300	A	63	300	4	1	0.326

Four pole RCCB type B.						
P1RC4P40B030	B	40	30	4	1	0.335
P1RC4P40B300	B	40	300	4	1	0.335
P1RC4P63B030	B	63	30	4	1	0.335
P1RC4P63B300	B	63	300	4	1	0.335
P1RC4P80B030	B	80	30	4	1	0.335
P1RC4P80B300	B	80	300	4	1	0.335

### General characteristics

These RCCBs are intended for the protection of people against indirect contact (electric shock) and of installations against fire hazards due to a persistent earth/ground fault current. Specifically to prevent electric shock, RCCBs must be rated with a rated residual current (IΔn) not exceeding 30mA so that these devices trip in the case of earth/ground fault only. They usually are connected in series with thermal-magnetic breakers which assure short circuit and overcurrent protection too. P1RC types have a IΔn of either 30mA or 300mA and are available with three different versions of residual current tripping, as follows:

Type AC – Tripping for earth/ground fault is ensured “for residual sinusoidal alternating currents, suddenly applied or slowly rising”. The symbol identifying Type AC is the following:

Type A – Tripping for earth/ground fault is ensured “for residual sinusoidal alternating currents and pulsating direct currents, suddenly applied or slowly rising”. In addition to the protection given by Type AC, this version protects against residual current with pulsating waveform. This can be caused by circuits connected with electronic equipment. The symbol identifying Type A is the following:

Type B – tripping is ensured for all conditions already covered by types AC and A. They also ensure tripping for high-frequency leakage currents up to 1000Hz and direct currents. They are particularly suitable for applications with inverters, UPSs and electric vehicle charging stations. The symbol identifying Type B is the following:

### Main features include:

- IEC rated current In: 25A, 40A and 63A
- Versions: 2P and 4P
- Type of operation: AC, A and B
- Pole width: 17.5mm / 0.69"
- Contact status with flag indicator
- Fixing on 35mm DIN rail (IEC/EN/BS 60715).

### Operational characteristics

- Dissipation per pole:
  - 1.1W for P1RC2/4P25... type AC or A
  - 2.9W for P1RC2/4P40... type AC, A or B
  - 7.2W for P1RC2/4P63... type AC, A or B
  - 9.7W for P1RC/4P80... type B
- IEC rated insulation voltage Ui: 400V
- IEC rated impulse voltage Uimp: 4kV
- IEC rated frequency: 50/60Hz
- IEC rated operational voltage Uc: 230VAC for 2P; 230/400VAC for 4P
- IEC rated residual operating voltage Ue: IΔn: 30mA; 300mA
- IEC short-circuit breaking capacity Icn: 10kA

### Certifications and compliance

Certifications obtained: TÜV-Rheinland (types AC and A), EAC. Compliant with standards: IEC/EN/BS 61008-1, IEC/EN/BS 61008-2-1 (all types); IEC/EN/BS 62423 (type B).

### Add-on blocks for P1RD...



P1X1011



P1X16230

Order code	Description	Qty per MCB	Qty per pkg	Wt
		n°	n°	[kg]

Auxiliary contact.				
P1X1011	1 changeover contact	1	10	0.040

Indicator contact for thermal-magnetic trip.

P1X1311	1 changeover contact	1	10	0.040
---------	----------------------	---	----	-------

Undervoltage trip release.

P1X14230	230V 50/60Hz	1	8	0.070
----------	--------------	---	---	-------

Shunt trip release.

P1X16230	110...415V 50/60Hz	1	8	0.070
----------	--------------------	---	---	-------

Padlockable attachment

P1X1810	Padlockable attachment for breaker control lever	1	10	0.001
---------	--	---	----	-------

### General characteristics

- Auxiliary and indicator contact width: 9mm/0.35" (0.5 module)
- Undervoltage and shunt trip release width: 18mm/0.71" (1 module)
- Maximum combination: 3 add-on blocks on MCB left side only of which 1 undervoltage or shunt release directly on MCB side and then 2 contacts of which 1 auxiliary and 1 indicator.

### Operational characteristics

- IEC rated impulse voltage Uimp: 4kV
- IEC rated operational current in AC: 6A 230V; 3A 400V (auxiliary contacts).

### Certifications and compliance

Certifications obtained: EAC, cURus (excluding P1X14230), UL (only P1X14230). Compliant with standards: IEC/EN/BS 60947-5-1, CSA C22.2 n° 5.

# 14 Miniature and residual circuit breakers

Residual current operated circuit breakers with overcurrent protection

## 1P+N - 10kA 2 modules



P1RE1N...

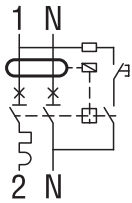

**new**

Order code	Curve	IEC In	IEC Icn	IEC IΔn	Mod. DIN	Qty per pkg	Wt
		[A]	[kA]	[mA]	n°	n°	[kg]
Single pole + neutral RCBO type AC.							
P1RE1NC06AC030	C	6	10	30	2	1	0.205
P1RE1NC06AC300	C	6	10	300	2	1	0.205
P1RE1NC10AC030	C	10	10	30	2	1	0.205
P1RE1NC10AC300	C	10	10	300	2	1	0.205
P1RE1NC16AC030	C	16	10	30	2	1	0.205
P1RE1NC16AC300	C	16	10	300	2	1	0.205
P1RE1NC20AC030	C	20	10	30	2	1	0.205
P1RE1NC20AC300	C	20	10	300	2	1	0.205
P1RE1NC25AC030	C	25	10	30	2	1	0.205
P1RE1NC25AC300	C	25	10	300	2	1	0.205
P1RE1NC32AC030	C	32	10	30	2	1	0.205
P1RE1NC32AC300	C	32	10	300	2	1	0.205
P1RE1NC40AC030	C	40	10	30	2	1	0.205
P1RE1NC40AC300	C	40	10	300	2	1	0.205
Single pole + neutral RCBO type A.							
P1RE1NC06A030	C	6	10	30	2	1	0.205
P1RE1NC06A300	C	6	10	300	2	1	0.205
P1RE1NC10A030	C	10	10	30	2	1	0.205
P1RE1NC10A300	C	10	10	300	2	1	0.205
P1RE1NC13A030	C	13	10	30	2	1	0.205
P1RE1NC16A030	C	16	10	30	2	1	0.205
P1RE1NC16A300	C	16	10	300	2	1	0.205
P1RE1NC20A030	C	20	10	30	2	1	0.205
P1RE1NC20A300	C	20	10	300	2	1	0.205
P1RE1NC25A030	C	25	10	30	2	1	0.205
P1RE1NC25A300	C	25	10	300	2	1	0.205
P1RE1NC32A030	C	32	10	30	2	1	0.205
P1RE1NC32A300	C	32	10	300	2	1	0.205
P1RE1NC40A030	C	40	10	30	2	1	0.205
P1RE1NC40A300	C	40	10	300	2	1	0.205

### General characteristics

These devices both detect and trip in the event of residual current and protect circuits in the case of short circuits and overcurrent. From a practical point of view, they integrate both functions of MCB and RCCB.

They have a C-type trip characteristic (instantaneous trip 5-10 times I<sub>n</sub>) and are used for inductive loads (mixed loads, resistive and inductive with low inrush current).

In addition, they have a rated residual current (I<sub>Δn</sub>) of either 30mA or 300mA and are available with two different versions of residual current tripping type AC or A as described on page 14-14.

Its main features are:

- IEC rated current I<sub>n</sub>: 6...40A
- Version: 1P+N
- Contact status with flag indicator
- Double control lever to distinguish the residual current tripping from short circuit or overcurrent tripping
- Trip characteristic: curve type C
- Fixing on 35mm DIN rail (IEC/EN/BS 60715).

### Operational characteristics

- Dissipation per pole: 3...13W
- Rated insulation voltage U<sub>i</sub>: 400V
- Rated impulse voltage U<sub>imp</sub>: 4kV
- Operating frequency: 50/60Hz
- Rated operational voltage U<sub>e</sub>: 230VAC
- Rated residual operating voltage I<sub>Δn</sub>: 30mA; 300mA
- IEC short-circuit breaking capacity I<sub>cn</sub>: 10kA

### Certifications and compliance

Certifications obtained: TÜV Rheinland, EAC.  
Compliant with standards: IEC/EN/BS 61009-1, IEC/EN/BS 61009-2-1.

## Add-on blocks for P1RE...



P1X1011



P1X16230

Order code	Description	Qty per MCB	Qty per pkg	Wt
		n°	n°	[kg]
Auxiliary contact.				
P1X1011	1 changeover contact	1	10	0.040
Indicator contact for thermal-magnetic trip.				
P1X1311	1 changeover contact	1	10	0.040
Undervoltage trip release.				
P1X14230	230V 50/60Hz	1	8	0.070
Shunt trip release.				
P1X16230	110...415V 50/60Hz	1	8	0.070
Padlockable attachment				
P1X1810	Padlockable attachment for breaker control lever	1	10	0.001

### General characteristics

- Auxiliary and indicator contact width: 9mm/0.35" (0.5 module)
- Undervoltage and shunt trip release width: 18mm/0.71" (1 module)
- Maximum combination: 3 add-on blocks on MCB left side only of which 1 undervoltage or shunt release directly on MCB side and then 2 contacts of which 1 auxiliary and 1 indicator.

### Operational characteristics

- IEC rated impulse voltage U<sub>imp</sub>: 4kV
- IEC rated operational current in AC: 6A 230V; 3A 400V (auxiliary contacts).

### Certifications and compliance

Certifications obtained: EAC, cURus (excluding P1X14230), UL (only P1X14230)  
Compliant with standards: IEC/EN/BS 60947-5-1, CSA C22.2 n° 5.

# 14 Miniature and residual circuit breakers

Dimensions [mm (in)]

## MINIATURE CIRCUIT BREAKERS

**P1MB...**

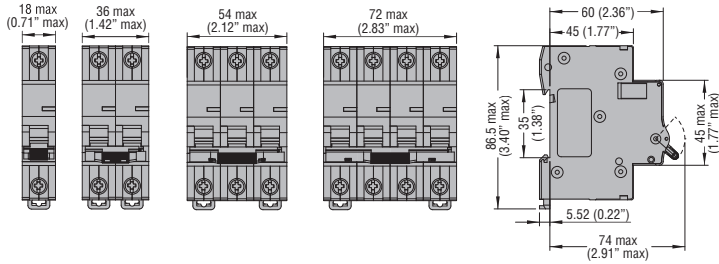

## ACCESSORIES

Add-on contacts

**P1X1011 - P1X0111S - P1X1011UH - P1X1311**

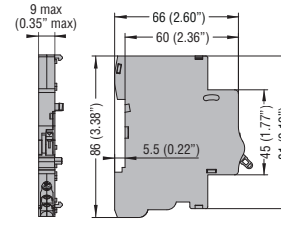

Undervoltage and shunt releases

**P1X14230 - P1X16230**

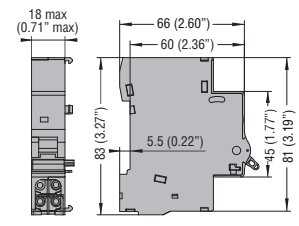

**P1MBUH... - P1MBUL...**

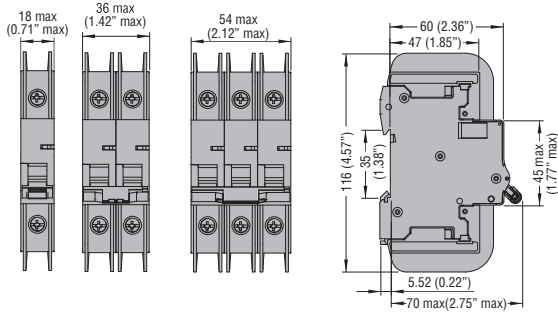

## SWITCH DISCONNECTORS

**P1MS...**

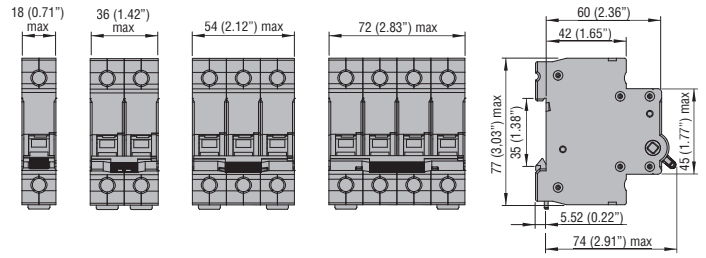

## MINIATURE CIRCUIT BREAKERS

**P2MB...**

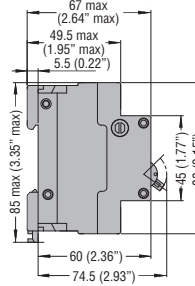
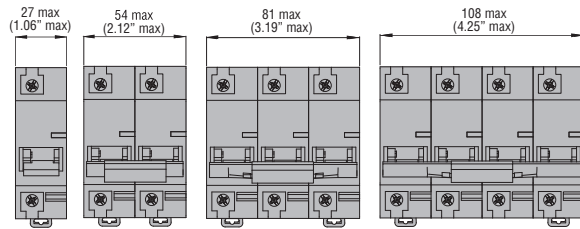

## ACCESSORIES

Add-on contacts

**P2X1011 - P2X1311**

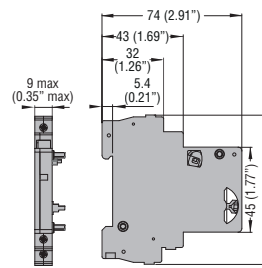

Shunt release

**P2X16230**

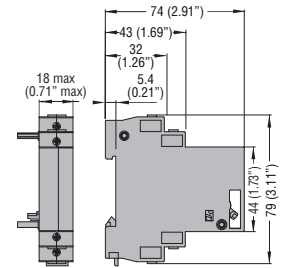

## RESIDUAL BLOCKS

**P1RA**

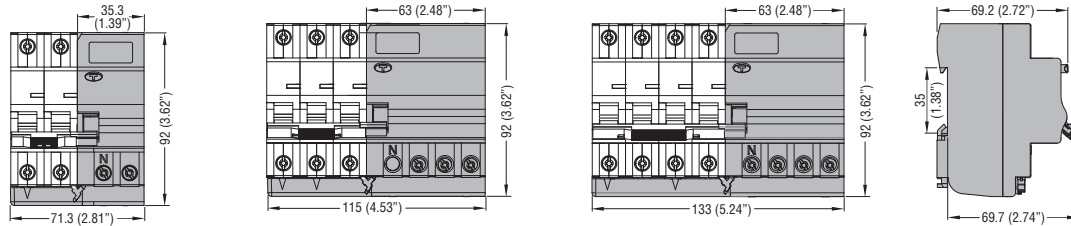

## RESIDUAL CURRENT OPERATED CIRCUIT BREAKERS

**P1RD...**

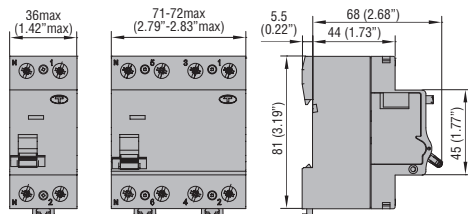

## RESIDUAL CURRENT OPERATED CIRCUIT BREAKERS WITH OVERCURRENT PROTECTION

**P1RE...**

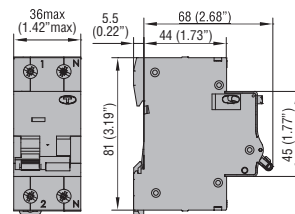

## Wiring diagrams

**P1X1011 - P1X1011S - P1X1011UH - P2X1011**

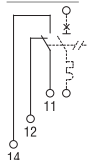

**P1X1311 - P2X1311**

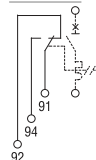

**P1X14230**

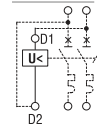

**P1X16230 - P2X16230**

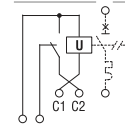

TYPE		P1MB1M...	P1MB1N...	P1MB...P...	P2MB	P1MS...	P1RA	P1RD...	P1RE...	
Description		Miniature circuit breakers	Miniature circuit breakers	Miniature circuit breakers	Miniature circuit breakers	Switch disconnectors	Residual blocks	Residual current operated circuit breakers	Residual current operated circuit breakers w/ overcurrent prot.	
Standards		IEC/EN/BS 60898, IEC/EN/BS 60947-2	IEC/EN/BS 60898, IEC/EN/BS 60947-2	IEC/EN/BS 60898, IEC/EN/BS 60947-2 UL 1077 - UL 489 <sup>①</sup>	IEC/EN/BS 60947-2 UL 1077	IEC/EN/BS 60947-3	IEC/EN/BS 61008-1 IEC/EN/BS 61008-2-1	IEC/EN/BS 61008-1 IEC/EN/BS 61008-2-1	IEC/EN/BS 61009-2-1	
IEC rated insulation voltage $U_i$	V	500	230	1000	400	1000	400	400	400	
IEC rated impulse withstand voltage $U_{imp}$	kV	4	4	4	6	4	4	4	4	
IEC rated operational voltage $U_e$	in AC	V	230	230	230 (1P, 1P+N) 230/400 (2P, 3P, 4P) <sup>②</sup>	230 (1P) 230/400 (2P, 3P, 4P)	230...240 (1P) 400...440V (2P, 3P, 4P)	230 (2P) 230/400 (3P, 4P)	230 (2P) 230/400(4P)	230
	in DC	V	—	—	80 (1P, 2P) <sup>④</sup>	80(1P)/125(2P) <sup>⑤</sup>	—	—	—	—
Rated frequency	Hz	50/60	50/60	50/60	50/60	50/60	50/60	50/60	50/60	
Maximum rated current	A	40	63	63	125	125	63	63	40	
Available rated current for types	A	2, 4, 6, 10, 13, 16, 20, 25, 32, 40	1, 2, 4, 6, 10, 16, 20, 25, 32, 40, 50, 63	1, 1.6, 3, 4, 6, 8, 10, 13, 16, 20, 25, 32, 40, 50, 63 <sup>②</sup>	80, 100, 125	30, 40, 63, 100, 125	40, 63	25, 40, 63 (80A B type only)	6, 10, 16, 20, 25, 32, 40	
Versions		1P+N	1P+N	1P, 2P, 3P, 4P	1P, 2P, 3P, 4P	1P, 2P, 3P, 4P	2P, 3P, 4P	2P, 4P	1P+N	
Tripping characteristic	curve	B-C	C	B-C-D	C-D	—	—	—	C	
Instantaneous tripping		Curve B: 3...5In Curve C: 5...10In	Curve B: 3...5In Curve C: 5...10In	Curve B: 3...5In Curve C: 5...10In Curve D: 10...14In	Curve C: 5...10In Curve D: 10...14In	—	—	—	Curve C: 5...10In	
Residual operation characteristic	type	—	—	—	—	—	A	AC, A, B	AC, A	
Rated residual current $I_{\Delta n}$	mA	—	—	—	—	—	30, 300	30, 300	30, 300	
Short circuit capacity (IEC/EN/BS)	kA	6 (Icn/Icu)	6 (Icn/Icu)	10 (Icn/Icu)	10 (Icu)	—	—	10 (Inc)	10 (Icn)	
Short circuit capacity (UL)	kA	—	—	7.5 (1P 240V) 5 (1P 277V) 7.5 (2,3,4P 480V)	5	—	—	—	—	
Mechanical life	cycle	20,000	20,000	20,000	10,000	20,000	10,000	4,000	20,000	
Maximum tightening torque of terminals	Nm	1.2	2	2	3.5	3.5	2	2	2	
	lb.in	10	15	15	31	31	15	15	15	
	Tool	PZ2	PZ2	PZ2	PZ2	PZ2	PZ2	PZ2	PZ2	
Conductor section min...max.	mm <sup>2</sup>	1...16	1...35	1...35	2,5...50	1...50	1...25	2,5...35	1...16	
	AWG	14...6	14...2	14...2	14...1/0	16...1	14...6	14...2	16...3	
<b>AMBIENT CONDITIONS</b>										
Temperature	Operating	°C	-40...+70	-40...+70	-40...+70	-40...+70	-25...+70	-25...+60	-25...+60	-25...+60
	Storage	°C	-40...+80	-40...+80	-40...+80	-40...+80	-25...+70	-40...+80	-40...+80	-40...+80
Max. altitude	m	2,000	2,000	2,000	2,000	2,000	2,000	2,000	2,000	
Pollution degree		2	2	2	3	3	2	2	2	
Mounting		35mm DIN rail (IEC/EN/BS 60715)								

### TRIP CHARACTERISTICS

#### Curve B

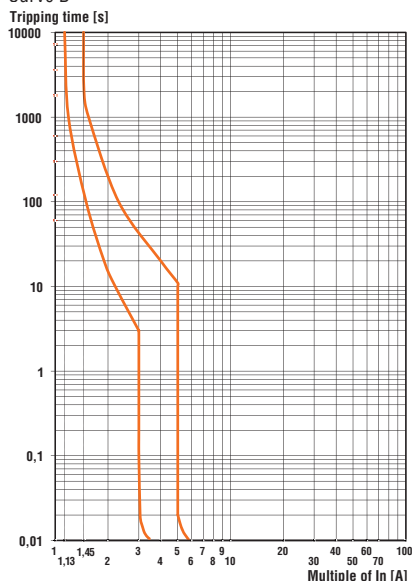

#### Curve C

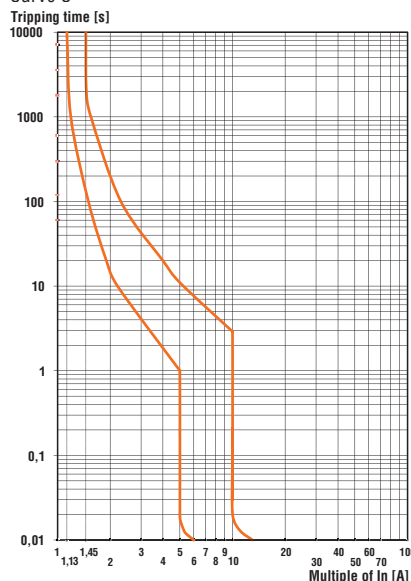

#### Curve D

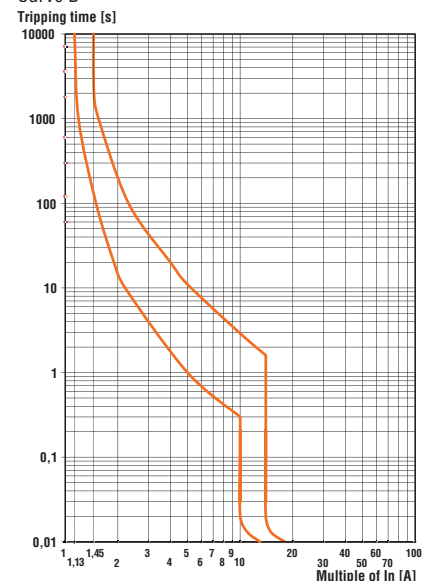

- ① UL489 only P1MBU... version; for the operational voltages for these devices refer to the pages for the chosen product.
- ② For the UL 489, P1MBU... versions, the following rated current currents are also available: 5, 7, 12, 15, 30, 35, 60 A.
- ③ For the UL 489, P1MBU... versions to 32A: 1P 277V; 2P and 3P 480V/277V. From 35 to 63A: 1P 120V; 2P and 3P 240V.
- ④ For the UL 489, P1MBU..., 1P 60VDC and 2P 125VDC.
- ⑤ For the UL 1077: 60VDC.